

KOBELCO

APRIL 1998

Vol.2 (No.2)

WELDING TODAY

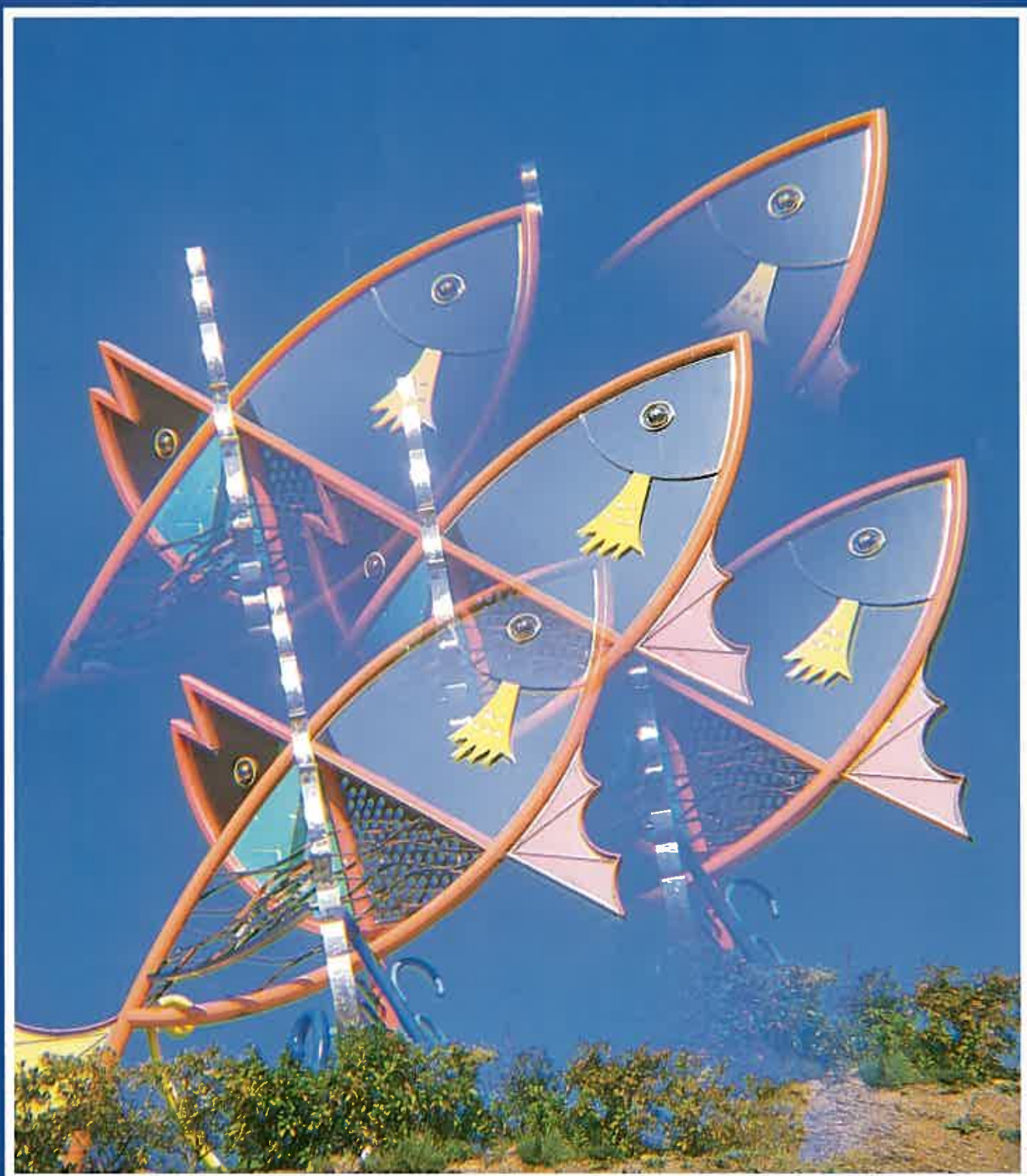

Curtis Kelly Saves Welding Costs by Using DW Stainless Wire



Vessels for cryogenic service, welded with DW-308L

Curtis Kelly, Inc. has provided leading edge technology and innovation in the design and fabrication of Stainless Steel and High Nickel Alloy chemical process equipment since 1969. The Chemical and Petrochemical industry regards Curtis Kelly, Inc. as a fabricator which provides unsurpassed quality, in a timely manner, at competitive prices.

William T. Grisham founded Curtis Kelly, Inc. in 1969 and currently resides as the Board Chairman. Thomas Hernandez, the Plant Superintendent and Phillip Hernandez, the Quality Control Manager demand Kobelco Flux Cored products to insure that they are fabricating with the highest quality Stainless Steel Flux Cored Wire in the market. They also know that they can rely on Kobelco Welding of America Inc. for technical support when needed.

The fabrication facility in Houston, Texas is very modern and fully equipped. Their diverse capabilities allow them to serve a variety of customers. While working with Stainless Steel and High Nickel Alloy materials, their facility is capable of rolling, cutting, polishing and welding in all stages of the fabrication process. In addition, efficiency is increased by turning rolls which are capable of handling projects up to 150 Tons. Skilled welders in their shop are trained and experienced with the FCAW, GMAW, GTAW, SAW, and SMAW processes. A key to their success is a commitment to high quality, experience, and longevity

of employees. These have been a major factor in producing consistent quality products.

While the majority of their products are designed and fabricated for the Chemical and Petrochemical industry, Curtis Kelly, Inc. works directly with a variety of engineering construction companies and end users domestically and internationally. The large vessel which is in the included picture is a good example of what Curtis Kelly, Inc. is capable of designing and manufacturing. This vessel was fabricated with 304L Stainless Steel and is currently being used for cryogenic service. It was welded with Kobelco DW-308L Flux Cored Wire.

Kobelco Flux Cored Wire was introduced to Curtis Kelly, Inc. in 1987. Since that time, Curtis Kelly, Inc. has proven to be one of our most valued customers. With the initial demonstration of the DW Stainless Flux Cored Wire, Curtis Kelly, Inc. was convinced that Kobelco wire was formulated and manufactured with superior quality. Since they are a manufacturer that prefers 100% CO₂ shielding gas, the ability of the DW Stainless Wire to run well with 100% CO₂ shielding gas is a great benefit. In addition, Kobelco Welding of America Inc. has proven to provide Curtis Kelly, Inc. with quick delivery of all available alloys.

Currently they are very instrumental in explaining the advantages that the Flux Cored Arc Welding process can provide to their customers. In bidding a project, they can show a customer direct cost savings that result from using the FCAW process over the SMAW process. In testing their projects, they can also show a customer the time and money that can be saved with fewer defects and reduced repairs due to the excellent weldability of the DW Stainless Flux Cored Wire.

The outlook for future business with Curtis Kelly, Inc. looks very promising. They are continuing to fabricate with the DW Stainless Flux Cored Wire, and are very anxious for Kobe Steel, Ltd. to introduce some High Nickel Alloy Flux Cored Wires in the United States. They feel that the chemical industry will keep their facility very busy for years to come.

(Reported by Mr. David Haynie, KWAI)

Message from the Editor



To our dearest readers of KOBELCO WELDING TODAY, I would like to send my sincere greetings at the occasion of the second issue.

The economic crisis, initially caused by the slump of currencies in the ASEAN countries last year, has depressed economies worldwide, and also has caused political problems in some nations. In the welding markets, we are concerned about the serious decrease in demand. In particular, the sales of automobiles and motorcycles in ASEAN countries has decreased to the level of nearly ten years ago, which is half of current years. These industries mostly use CO₂ arc welding with solid wires. The consumption of solid wire, therefore, has decreased sharply, and the amount of newly purchased welding power sources is at a lower level. This economic crisis also has seriously affected financial markets. In some cases, distribution of welding consumables in demand has stagnated because of the difficulty in raising funds.

On the other hand, several trade fairs related to the welding field are scheduled to be held worldwide this year: In April, Kobe Steel will exhibit highly efficient welding procedures focusing on flux cored wires at the Tokyo International Welding Fair, and followed by AWS Welding Show in Detroit. In May, we will introduce welding consumables and procedures suitable for the Chinese market at the Beijing Essen Welding Fair. In June, we will demonstrate the appeal of the LB-52U electrode at the Moscow Oil & Gas Fair by stressing its long history of reliability in the site welding of gas pipelines. And, we have a plan to introduce a series of stainless welding consumables at Singapore Weldtech Asia in December. We are looking forward to seeing you at the trade fairs in every countries. Please visit our booth, and I look forward to seeing you soon.

Tetsuo Konohira,

General Manager, IOD, Welding Div., Kobe Steel, Ltd.

Contents

User Reportage	1
◇ Curtis Kelly saves welding costs by using DW stainless wire	
Message from the Editor	2
◇ Clear the depression away with trade fairs around the world	
Technical Report	3-8
◇ Primer-proof flux cored wire, "MX-200", for fillet welding	
◇ Reliable low hydrogen electrode, "LB-52", for all-position welding	
◇ Versatile stainless electrode, "NC-38L", for all-position welding	
KOBELCO Group News	9
◇ Hot activities in the Thai Shinyokai	
Feature Article	10
◇ KOBELCO's new partner	
Editorial Postscript	10



Cover picture:

A sculpture of sea breams, yellowtails, and sprays of waving high seas reflect lively fishermen being pleased with a big haul.

■Produced by: Mr. K. Misawa

■Photographed by: Mr. A. Misono'o(Japanese Adv. Photographer's Association)

MX-200

(AWS A5.20 E70T-1)



MX-200 Can Release You From the Headache of Porosity in Fillet Welding of Shop-Primer-Paint-Coated Steel Plates in Horizontal and Flat Positions

Basic Characteristics of MX-200

MX-200 is a metal type flux cored wire suited for fillet welding of mild steel and 490N/mm² high tensile steel painted with shop primer. The M stands for Metal, while X reflects the expectation excellence. MX-200 was developed as an exclusive-use flux-cored wire for fillet welding in horizontal and flat positions with CO₂ gas shielding.

How Shop Primer Causes Porosity

Shop primer is a paint applied to the surface of steel plates in order to protect them from rusting during fabrication. Shop primer is often used in shipbuilding and bridge construction. Shop primer can be a predominant cause of porosity in fillet welds. Porosity is believed to occur because the arc heat decomposes shop primer into several gases and metallic vapors, which form pores in the weld metal. The degree of porosity depends on the type and coating thickness of the shop primer, the type of welding wire and welding parameters.

Advantages of MX-200

A typical flux-cored wire can overcome the porosity problem caused by shop primer if welding speed is lowered or if the shop primer is partly removed from where the fillet welds will be laid on.

However, if you need to do fillet welding much more effectively, using higher welding speeds and without removing shop primer, you will encounter the porosity problem.

Fig. 1 shows the results of testing different types of welding wires and welding speeds for porosity in fillet welding. It clearly shows that MX-200 is far more resistant to shop primer than conventional flux-cored wire at a wide range of welding speeds.

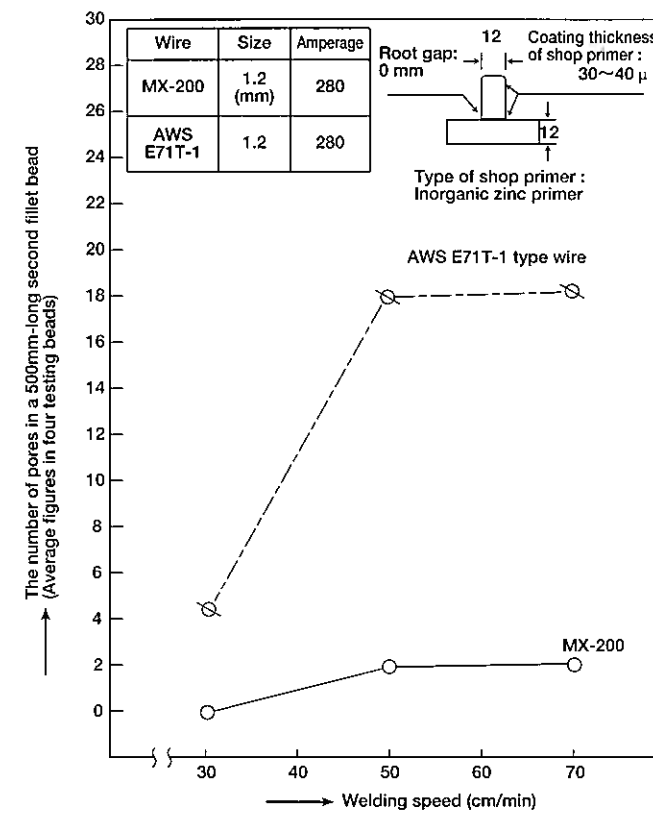

Fig.1 The results of testing the porosity susceptibility of flux-cored wires in fillet welding shop-primer-painted steel plates

Besides better resistance to shop primer, MX-200 provides the following advantages:

- (1) Glossy, smooth bead appearance due to thin, regular slag covering
- (2) Regular bead profile at a wide range of welding speeds due to excellent fusion at the toe of the fillet weld
- (3) Less spatters due to smooth droplet transfer
- (4) Smaller leg length (approx. 4mm) provided more easily due to a stable arc at lower amperage.

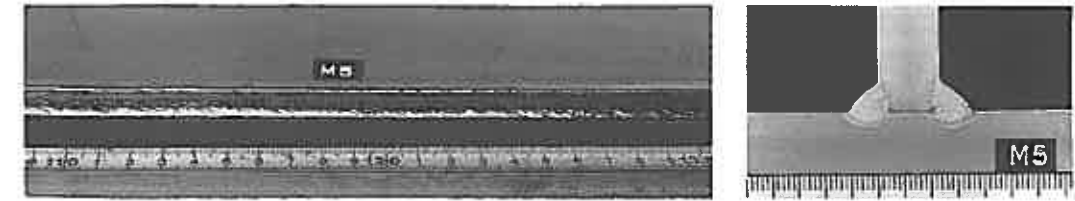

Fig.2 Bead appearance and cross-sectional view of a fillet weld (MX-200, 1.2mm φ, 280Amp. 28-32Volt, 50cm/min)

Fig. 2 shows an example of bead appearance and a cross sectional profile of a fillet weld using MX-200. It shows smooth, regular bead appearance and regular leg length with proper penetration at the root of the fillet weld.

Besides excellent resistance to shop primer and usability, MX-200 is well-suited for high speed welding. Fig. 3 shows the relationship between welding speed and leg length of fillet welds. You can determine the required welding speed for different leg lengths using this figure.

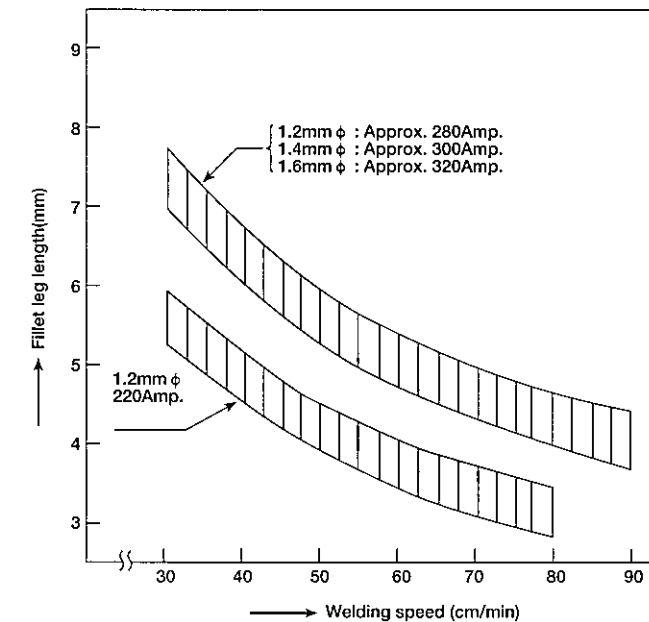

Fig.3 The relationship between welding speed and fillet leg length

Suitable for Automatic Welding

MX-200 persistently earns a good reputation among users in shipbuilding, bridge construction, machinery fabrication, rolling-stock fabrication, steel structure fabrication due to the outstanding features as discussed above:

- (1) Excellent resistant to shop primer
- (2) Excellent usability

(3) Excellent high speed weldability

MX-200 can be used in automatic welding as well as semi-automatic welding. Fig. 4 shows an example of an automatic welding process in which a portable fillet-welding carriage and MX-200 are used in fillet welding of longitudinal components in shipbuilding.



Fig.4 Fillet welding of longitudinal components by using a portable fillet welding carriage and MX-200 in shipbuilding (By courtesy of Tsuneishi Shipyard, Japan)

Kobe Steel is sure MX-200 will provide you with efficient fillet welding at higher welding speeds and, with increased mechanization in your workshops.

LB-52

(AWS A5.1 E7016)

The No.1 Low-Hydrogen Type Electrode for Both Mild Steel and 490N/mm² High Tensile Steel Suited for Almost Limitless Applications.

Inception of LB-52

LB-52 was developed around 1958. L stands for Low Hydrogen, while B symbolizes a slag-shielding covered electrode. 52 refers to the level of approximate tensile strength of the deposited metal when it was developed.

How Low the Hydrogen Content

The E7016 electrode is designated as a Low Hydrogen Type, stressing the very important factor of lower hydrogen content in the deposited metal. Hydrogen is a predominant element that accelerates cracking in welds. Fig. 1 compares the hydrogen content in deposited metals of several types of covered electrode. It clearly shows the low-hydrogen type releases the lowest hydrogen content.

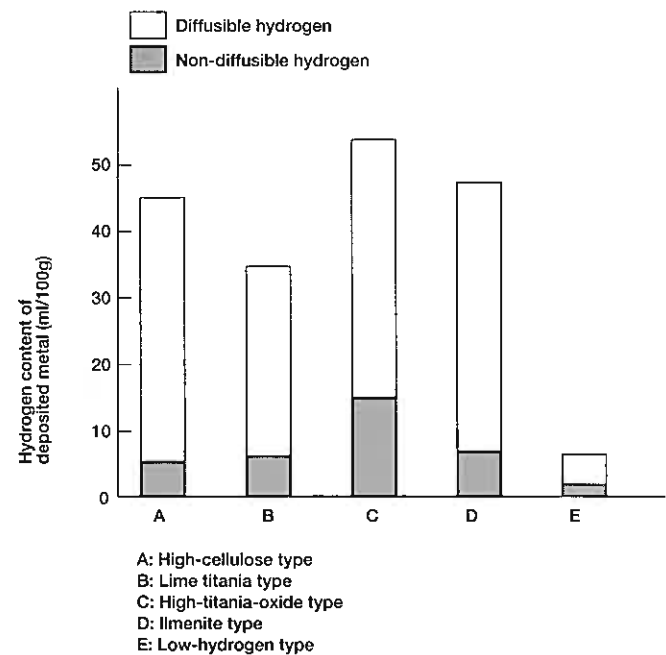

Fig.1 Hydrogen content in deposited metals of different types of covered electrode



Outstanding Features of LB-52

The outstanding features of LB-52 among other E7016 electrodes are:

- (1) Excellent usability in out-of-position welding: better arc concentration, easier slag removal, smoother bead appearance
- (2) Excellent mechanical properties: constant tensile strength, higher impact value
- (3) Excellent X-ray soundness

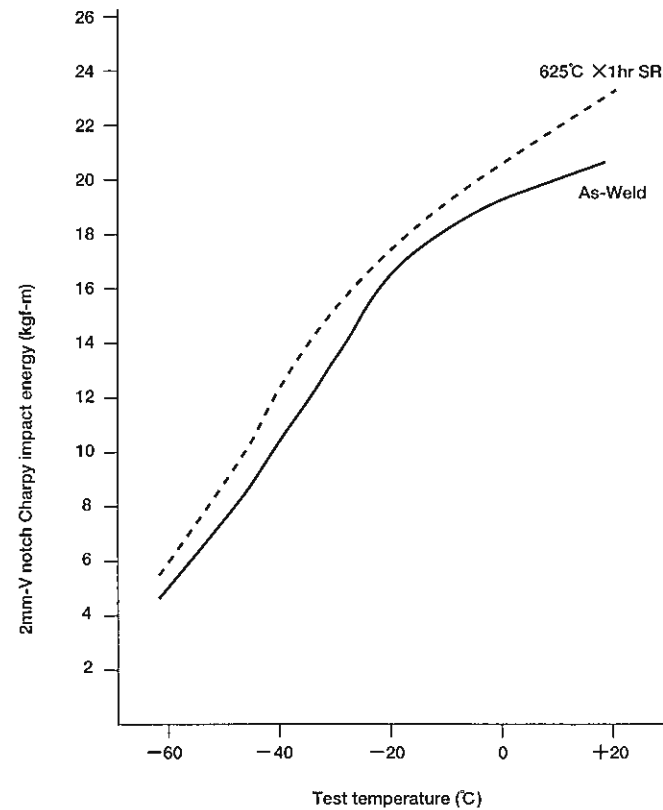

Fig.2 Impact test results of LB-52 deposited metal both as-welded and postweld heat treated

Fig. 2 shows the results of Charpy impact testing with 2mmV-notch specimens at a wide range of testing temperatures. Because of this high impact strength in both as-welded and postweld-heat-treated condition, LB-52 can be used for low-temperature applications down to -20°C, in addition to room temperature and elevated temperature applications.

Highly Reputed for 40 Years

Since it was launched, LB-52 has seen its features refined and its markets expanded. Kobe Steel pursues keen quality control in order to maintain the outstanding features of LB-52 produced in Japan and overseas. The maintenance of quality is an important factor in persistently earning a high reputation for LB-52 in almost limitless applications in such various fields as pressure vessels, storage tanks, pipelines, machinery, offshore structures, ships, bridges, and steel structures. Kobe Steel is sure LB-52 will be a reliable electrode for your workshop.

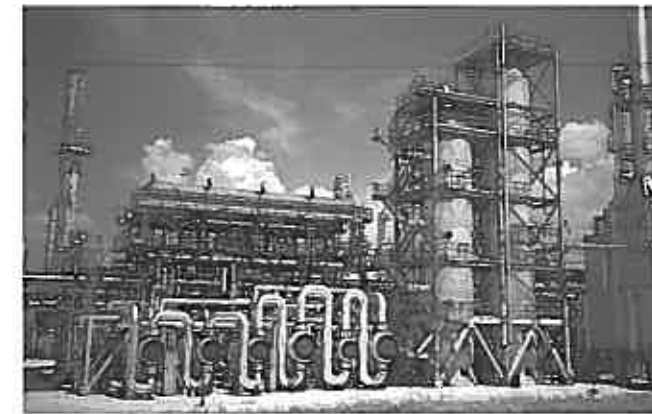

Fig.3 LB-52 is a must for plant construction

How to Use LB-52

The choice of LB-52 can prevent cracking in welding poor-weldability base metals that contain a high percentage of carbon, or that have thick sections. This is because of the merit of lower hydrogen and higher ductility of the weld metal.

The choice of LB-52 can be the solution for passing stricter X-ray test. This is because of excellent arc concentration and fusion to the groove face.

The choice of LB-52 can be the solution for fulfilling stricter requirements for tensile strength and impact value in both as-welded and postweld heat-treated condition lot by lot. This is because of Kobe Steel's keen quality control in every lot of production. However, you cannot obtain these benefits unless you follow some of the following precautions:

- (1) Re-dry LB-52 at 300 - 350°C for 30 - 60 minutes before use for every four-hour exposure to air without wetting unless otherwise specified. This is because the coating flux tends to pick up moisture in the air as shown in Fig. 4. Moisture can be a source of hydrogen in weld metal. Fig. 4 clearly shows that higher temperatures and humidity accelerate the moisture pick up.

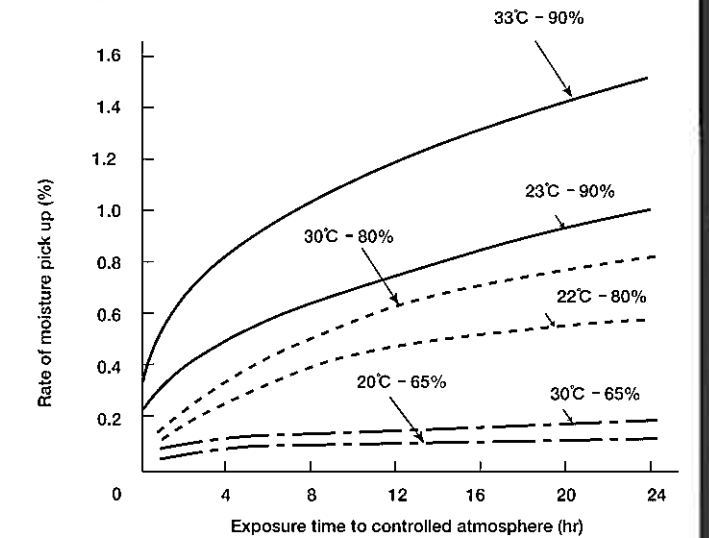

Fig.4 The moisture pick up vs. several temperatures and levels of humidity of the controlled testing atmosphere

- (2) Use the backstep technique at arc starting to prevent the occurrence of porosity at the starting area of the bead as illustrated in Fig. 5. This is common practice for all low hydrogen type electrodes.

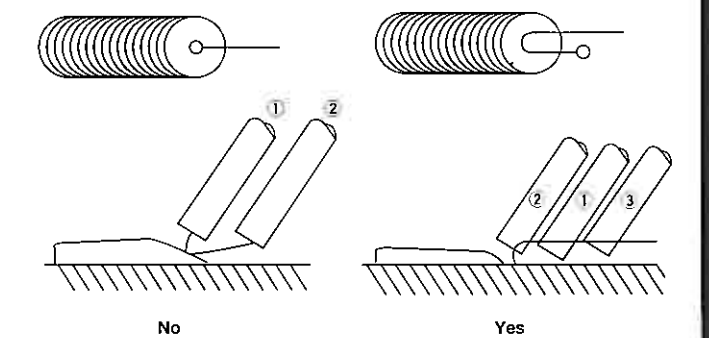

Fig.5 The backstep technique prevents porosity at the arc starting area of the weld bead

NC-38L

(AWS A5.4 E308L-16)



NC-38L is a Versatile Electrode for Welding 304L and 304 Stainless Steel in All Positions. Suitable for Various Applications at Low and Elevated Temperatures.

Inception of NC-38L

NC-38L was developed in 1961. N is for Nickel, while C is for Chromium. These are major alloying elements in austenitic stainless steel. 38 was coined from the classification of E308L. L is for Low Carbon.

Basic Characteristics of NC-38L

NC-38L is a lime-titania type electrode, classified as AWS E308L-16. NC-38L is suited for welding by both AC and DCEP (DC Electrode Positive) polarity. The deposited metal is of a low-carbon, 18%Cr-8%Ni type.

Outstanding Features of NC-38L

Among all the various brands classified as E308L, NC-38L has outstanding features:

- (1) Less susceptibility to hot cracking due to the properly controlled ferrite percentage. Fig. 1 shows a typical location of NC-38L in a Schaeffler diagram.

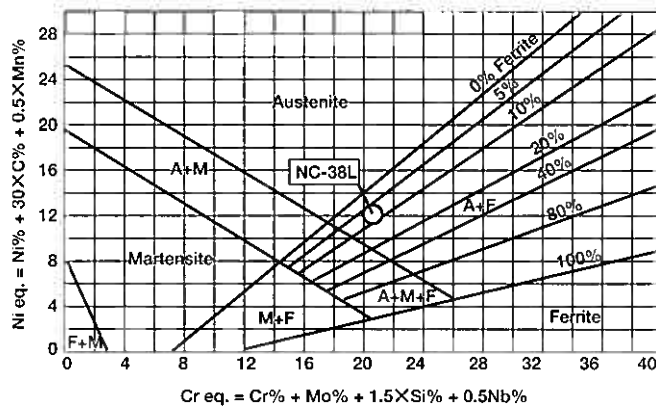

Fig.1 Schaeffler diagram

Fig. 2 shows the microstructure of NC-38L deposited metal in comparison with that of 304L type base metal. It clearly shows how different the microstructures are.

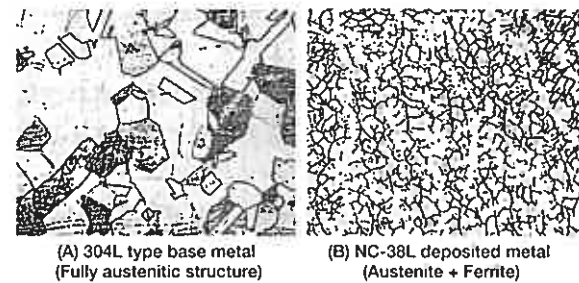

Fig.2 Microscopic structures of 304L type base metal and NC-38L deposited metal (100X)

This is because, the base metal does not contain the ferrite to be a fully austenitic structure, while the deposited metal contains a certain percentage of ferrite as shown in Fig. 1. This ferritic network structure in the austenitic matrix is effective at preventing the hot cracking that may take place during welding. However, an excessive ferrite content has adverse effects, so it must be properly controlled.

- (2) Superior corrosion resistance due to sophisticated design of chemical compositions. Table 1 shows corrosion test results of two different types. In the 65% nitric acid test (Huey test), the average weight loss of the test specimens is measured to know the intergranular corrosion resistance to the acids. The copper sulfate sulfuric acid test (Strauss test) checks the occurrence of cracking in bent specimens to know the intergranular corrosion resistance to the acids.

Table 1 Typical corrosion test result of NC-38L deposited metal

65% Nitric acid test (Huey test)	
As weld	0.00052 ipm
650°C x 2hr, AC	0.00069 ipm
1050°C X 30min, WQ	0.00047 ipm
Copper sulfate sulfuric acid test (Strauss test)	
650°C x 2hr, AC	No defect

- (3) Stable tensile and impact strength of the deposited metal due to properly controlled chemical compositions.
- (4) Properly balanced usability in out-of-position welding.

Highly Reputed for Nearly 40 Years

Since it was launched, NC-38L has seen its features refined and its markets expanded. Kobe Steel pursues keen quality control in order to maintain the outstanding features of NC-38L produced in Japan and Thailand. This quality control is an important factor in the product's persistently high reputation, particularly for welding pressure vessels, tanks and pipes in such sophisticated equipment industries as oil refineries,



Fig.3 NC-38L is an indispensable electrode for construction of energy process plants

chemical plants, and energy plants.

How to Use NC-38L

The choice of NC-38L can be the way to fulfill strict requirements for ferrite content, corrosion resistance and mechanical properties.

The choice of NC-38L can be the way to get sound

welds in out-of-position welding by both AC and DCEP polarity.

When you use NC-38L, however, the following instructions should be noted in order to get the best results.

- (1) No preheating should be used when you weld 304L and 304 type stainless steel. Rather, the interpass temperature should be kept at 150°C or lower. This is to minimize the heat-affected zone, and thereby to minimize weld decay.
- (2) Use proper welding currents. This is to prevent an electrode from the burning caused by Joule's heat. Note that a Cr-Ni stainless steel electrode has electrical resistance approximately 5 times that of a carbon steel electrode, and has low thermal conductivity approximately 1/3 that of a carbon steel electrode. This means the Joule's heat produced in a Cr-Ni stainless electrode tends to concentrate, which causes the electrode burn. In addition, the electrode burn adversely affects usability and mechanical properties.
- (3) Re-dry NC-38L at 150-200°C for 30-60 minutes before use when it picks up moisture. If an electrode picks up moisture, the arc blow becomes stronger, which causes spatters, irregular bead appearance and undercuts.

Hot Activities in Thai Shinyokai

สวัสดิ์ครับ (sa waht dee krahp)

Hello from Thai-Kobe Welding which is celebrating its 30th anniversary this year. Most readers probably know that the economy slumped after the Thai Baht was devalued last July. The devaluation and the resulting recession have caused many Japan-Thai joint ventures to struggle. Automobile and motorcycle companies in particular - and TKW, too - are now working hard to overcome the current difficulties.

During this recession, TKW's sales have been sluggish. We know, however, that we will surely overcome the problems with the cooperation of all our allies in the Thai Shinyokai: the integrated distribution network organized by the sales agents authorized by TKW. The Thai Shinyokai was established in 1992, and is entering its sixth year now. Earlier, the Thai Shinyokai was comprised of 3 Sales Representatives (SR), 4 Authorized Distributors (AD), 8 Area Authorized Distributors(AAD), and TKW. Since then, 19 Metropolitan Qualified Distributors(MQD) and more 5 AADs have joined. Therefore, there are 39 sales agents and TKW within this sales network now.

The Thai Shinyokai meeting is held 3 times a year (including the meeting that is combined with the ASEAN Shinyokai) to report and discuss our activities and policies. Coming from Japan, I have been surprised to notice that the wives of the owners are very much involved in taking care of their company's finance, and, therefore, are important participants in the Shinyokai meetings. In fact, it sometimes seems they are the "bosses" - in their business as well as in their private life. I've seen wives working hard to motivate their husbands in their business. They are cheerful and good caretaker. They also play an important role in the party after the meeting. They lead games, Karaoke, and Thai dancing, while their husbands often sit in the shade. It is easy to see how energetic they are. When I tried to limit access to the meetings to only the owners, thinking that they would be released from their wives, my idea met such strong opposition from the wives that it was in



Mr. Chan and his wife Mrs. Chanya being encouraged by the chairman, Mr. Bandit, ETK when all the Thai Shinyokai members visit the AAD, KTM(Above)

vain.

Since 1997, we have also had a Mini Shinyokai, which is organized by key salesmen and saleswomen who work for the Thai Shinyokai sales agents. During the Mini Shinyokai activities, they study the selling points of the TKW brands, they work on developing good personal communication in order to improve the in-house share of TKW brands, and also to develop a "pro-Kobe mind". Because the participants are younger than those in the Thai Shinyokai, their activities create a cheerful mood which helps clear away the black clouds of the economic recession.

We also use 5 different activities for developing pro-Kobe users: Market Cultivate Campaign (MCC), Train Agent (TA), Technical Presentation (TP), Target Group Seminar (TGS), Welding Skill Contest (WSC). These activities are based on TKW's strategy to grow pro-Kobe users by stepping away from price competition.

17 Thai staff of TKW's Thai Marketing Department, who are around 28 years old on average, support all of these activities reported above, and take care of the Thai market - an area 1.4 times that of Japan. We are expanding the Thai Shinyokai, targeting 50 agents in total for 2000. Wishing your support for the Thai Shinyokai.

(Reported by Mr. T. Okuzumi, Director, TKW)

KOBELCO's New Partner in the Philippines



The building of IWC

Industrial Welding Corporation (IWC) is ready to produce and supply KOBELCO RB-26 (E6013) and LB-52-18 (E7018) electrodes under license from Kobe Steel. IWC is expected to produce and supply 300MT of these electrodes per month for the Philippine domestic market. IWC is the second-ranking producer of welding electrodes, located in Metro Manila in the Philippines.

IWC is the sixth production base in the ASEAN district among Kobe Steel's subsidiary and licensee companies following Thai-Kobe Welding (established in 1968), Kobe Welding Singapore (1979), Intan Pertiwi Industri (1977), Kobe Mig Wire Thailand (1988), and Kobe Welding Malaysia (1993).

Kobe Steel supports IWC so that they can produce and supply RB-26 and LB-52-18 electrodes with quality as high as Kobe Steel produces in order to earn a good reputation in the Philippine market. Kobe Steel's support will center on technical collaboration in order to maintain the fame these brands have earned in the Asian markets.

Main Office: Industrial Welding Corporation
(Welding Resources International Inc.)

Licensed Year: 1997

Address:

No.10, R. Jacinto Street, Canumay, valenzuela, Metro Manila, 1440, The Philippines.

Tel: 02-292-6968(Country code: 63)

Fax: 02-292-6974(Country code: 63)

Number of Employees

(Japanese/National staff):

220 (0 / 220)

Language: Tagalog, English

Range of Products:

(1) Welding electrode for mild steel: RB-26 (E6013)

(2) Welding electrode for mild steel and 490N/mm² high tensile steel: LB-52-18 (E7018)

Sales Window: Mr. Johnny G. Ong, President

Editorial Postscript

We have edited this issue so that the technical report occupies more pages than the last issue. We, therefore, could have reported technical background of each welding consumable. We will be pleased, if this report has helped you to understand the technical advantages of MX-200, LB-52, and NC-38L.

Several welding fairs will be held worldwide this year:

(1) Tokyo Welding Exhibition, Tokyo, Japan, April 8-11

(2) American Welding Show, Detroit, USA, April 28-30

(3) Beijing Essen Welding Fair, Beijing, China, May 26-30

(4) Neftegaz Oil & Gas Fair, Moscow, Russia, June 22-26

(5) Weldtech Asia 98, Suntech City, Singapore, December 1-4

Kobe Steel is ready to exhibit welding consumables and related equipment at every fair. Kobelco Welding of America Inc will be an exhibitor at the American Welding Show.

KOBELCO WELDING TODAY

April 1998, Vol.2 (No.2)

Publisher : The International Operations Dept., Welding Div., Kobe Steel, Ltd.

Printer : Fukuda Printing Co., Ltd.

Editor : KOBELCO WELDING TODAY Editorial Staff

URL : <http://www.kobelco.co.jp>

WELDING CONSUMABLE

KOBELCO

THE WORLDWIDE MANUFACTURER

GLOBAL MANUFACTURING AND SALES BASES

JAPAN :

KOBE STEEL, LTD. Welding Division
International Operations Dept.
KOBELCO Bldg., 3-2Toyo 2-chome, Koto-ku, Tokyo 135-8381
JAPAN
Tel. (81)3 5634-5031 Fax. (81)3 5634-5047

EUROPE :

KOBELCO WELDING OF EUROPE B.V.
Eisterweg 8, 6422 PN, Heerlen, The Netherlands
Tel. (31)45-547-1111 Fax. (31)45-547-1100

USA :

KOBELCO WELDING OF AMERICA INC.
7478 Harwin Drive, Houston, Texas 77036, USA
Tel. (1)713 974-5774 Fax. (1)713 974-6543

KOREA :

KOBE WELDING OF KOREA CO., LTD.
21-14, Palryong-Dong, Changwon, Kyongnam, Republic of
Korea
Tel. (82)551 92-6886 Fax. (82)551 92-7786

SINGAPORE :

KOBE WELDING (SINGAPORE) PTE. LTD.
20, Pandan Avenue, Jurong, Singapore 609387, Republic of
Singapore
Tel. (65)2 68 27 11 Fax. (65)2 64 17 51

THAILAND :

THAI-KOBE WELDING CO., LTD.
500, Soi 1, Bangpoo Industrial Estate, Sukhumvit Road,
Praeksa, Samutprakarn 10280, Thailand
Tel. (66)2 324-05 88 - 91 Fax. (66)2 324-07 97

KOBE MIG WIRE (THAILAND) CO., LTD.

491, Soi 1, Bangpoo Industrial Estate, Sukhumvit Road,
Praeksa Samutprakarn 10280, Thailand
Tel. (66)2 324-05 88 - 91 Fax. (66)2 324-07 97

MALAYSIA :

ST KOBE WELDING (MALAYSIA) SDN. BHD.
Plot 502, Jalan Perusahaan Baru, Kawasan Perusahaan
Prai, 13600 Prai, Malaysia
Tel. (60)4-3905792 Fax. (60)4-3905827

INDONESIA :

P.T. INTAN PERTIWI INDUSTRI
(Technically-Collaborated Company)
Jalan P Jayakarta 45, Block A/27,
Jakarta 11110, Indonesia
Tel. (62)21-639-2608 Fax. (62)21-649-6081

PHILIPPINES :

WELDING RESOURCES INTERNATIONAL INC.
(INDUSTRIAL WELDING CORPORATION)
(Technically-Collaborated Company)
No. 10, R. Jacinto Street, Canumay, Valenzuela, Metro Manila,
1440, Philippines
Tel. (63)2-292-6968 Fax. (63)2-292-6974

INTERNATIONAL SLOGAN KOBELCO WELDING GROUP

Q T Q

Quality Products Technical Support Quick Delivery